



CXJ-4030C

Description:

CXJ-C series automatic case erector can complete the process of carton erecting, vertical forming, bottom flaps folding and bottom tape sealing automatically according to programs.

Features:

High efficiency, high speed, easy size changeover, stable and safe in operation, reliable in performance, etc

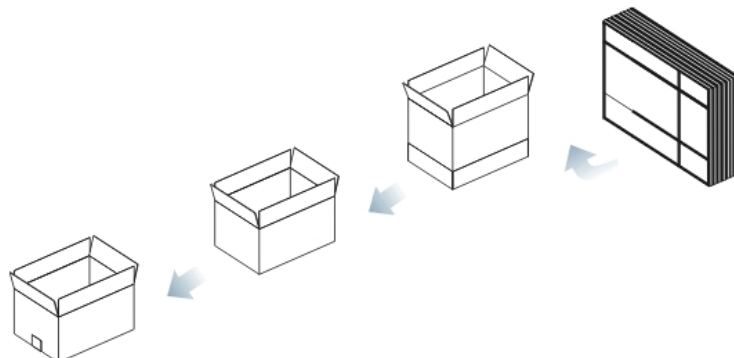
Workflow:

Parameters:

	CXJ-4030C	CXJ-6040C	CXJ-8055C
Voltage (V/Hz)	AC 220/50 110/60		
Power (W)	180		
Gas Pressure (Mpa)	0.5~0.6		
Capacity (CTNS/min)	≤12	≤10	≤8
Min. Carton Size (L×W×H) (mm)	200×150×100	250×200×150	400×250×300
Max. Carton Size (L×W×H) (mm)	400×300×300	600×400×400	800×550×550
Height of Table (mm)	700+(0-30)	800+(0-50)	
Adhesive Tape Used	BOPP、PVC、Kraft Paper Tape		
Width of Adhesive Tape (mm)	48	60 72	
External Dimensions (L×W×H) (mm)	2000×1550×1750	2300×1700×1970	2300×1700×1970
Net Weight (kg)	500	545	600